



BDKF-R

HARİCİ MOTORLU DİKDÖRTGEN KANAL FANI
Geriyeye Eğimli

Bahçivan BDKF-R dikdörtgen kanal fanları uygulama alanının sınırlı olduğu sistemlerde düşük ve orta hacimde havalandırma ihtiyaçlarının karşılanması için tasarlanmıştır. Motor hava akımı dışarısında olduğundan dolayı 120° sıcaklığa kadar dayanıklıdır.

Teknik Resim

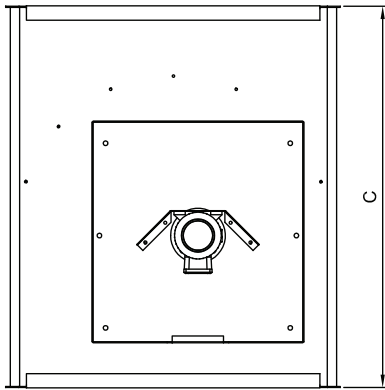
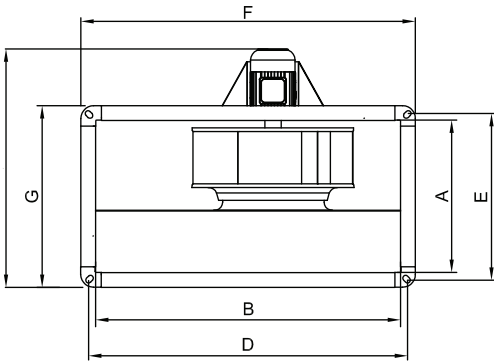

MALZEME

: Gövdesi galvaniz sacdan,
Radyal fan, geriye eğimli kanat yapısı ile galvaniz sac'dan üretilmiştir.

YALITIM SINIFI

: Class F

STANDART

: EN 60335-1, EN 60335-2-80

HIZ KONTROLÜ

: Opsiyonel kontrol cihazıyla sağlanabilir.

KULLANIM ALANLARI

: Mutfak aspiratörleri, otel, otopark ve kamu binaları, alışveriş merkezleri vb. alanlarda kullanıma uygundur.

TİP	VOLTAJ	FREKANS	GÜÇ	AKIM	DEVİR	DEBİ	SES SEVİYESİ	AĞIRLIK
	V	Hz	KW	(A)	d/d	m ³ /h	dB(A)	kg
BDKF-R 315	230/380	50	0,25	1,8/0,81	1440	3000	68	35
BDKF-R 355	230/380	50	0,37	2,6/1,15	1420	3500	69	36
BDKF-R 400	230/380	50	0,55	3,3/1,5	1470	4700	75	49
BDKF-R 450	230/380	50	1,1	7,1/2,6	1450	6000	78	52
BDKF-R 500	230/380	50	1,5	9,3/3,5	1400	8400	80	74
BDKF-R 560	230/380	50	2,2	13,4/5,1	1440	10500	80	91

Aksesuarlar

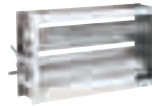

BSC-F

BDEB

BDH

BDKS

TİP	A	B	C	D	E	F	G	H
BDKF-R 315	350	600	760	620	370	650	400	550
BDKF-R 355	350	600	760	620	370	650	400	550
BDKF-R 400	400	700	800	720	420	750	450	630
BDKF-R 450	400	700	800	720	420	750	450	630
BDKF-R 500	500	800	920	820	520	850	560	780
BDKF-R 560	500	1000	1050	1030	530	1060	560	780

Ölçüler mm cinsindedir.

